



# SSLO



КАТАЛОГ КРЕСЕЛ

2015

1

КРЕСЛА РУКОВОДИТЕЛЯ  
СЕРИИ УЛЬТРА

страницы **3-18**

2

КРЕСЛА РУКОВОДИТЕЛЯ

страницы **19-33**

3

КРЕСЛА ОПЕРАТОРА

страницы **34-46**

4

СТУЛЬЯ ДЛЯ ПОСЕТИТЕЛЕЙ

страницы **47-49**

5

ОТДЕЛОЧНЫЕ МАТЕРИАЛЫ

страницы **50-54**

## УСЛОВНЫЕ ОБОЗНАЧЕНИЯ:

	Максимальная нагрузка на кресло 100 кг		Крестовина $\varnothing$ 600 мм. Материал — полиамид стеклопоноплащенный
	Спинка и сидение отдельные		Крестовина $\varnothing$ 700 мм. Материал — шлифованный алюминий
	Спинка и сидение монолитные		Крестовина $\varnothing$ 600 мм. Материал — хромированная сталь
	Вес кресла в упаковке (брутто)		Крестовина $\varnothing$ 680 мм. Материал — полиамид стеклопоноплащенный
	Объем упаковки		Регулируемые по высоте подлокотники
	Ролик $\varnothing$ 11 мм. Полиамид стеклопоноплащенный		Эргономика на спинке и/или на сидении
	Ролик $\varnothing$ 11 мм. Прорезиненная рабочая часть. Полиамид стеклопоноплащенный		Количество стульев в стопке
	Хромированный газ-лифт		Объем стопки с креслами
	Короткий газ-лифт		
	Средний газ-лифт		
	Топ-Ган: механизм качаний с фиксацией в рабочем положении		
	Механизм качания «Люкс»: с фиксацией в любой позиции		
	Мультиблок: механизм качания с фиксацией в любом положении		
	СРТ: механизм с 3-ми регулировками: высота спинки, глубина сидения, угол отклонения		
	PROFI: Пружинно-винтовой механизм с регулировкой жесткости отклонения спинки		
	661: механизм с фиксацией спинки в любом положении		
	Овал: соединитель-овалина с двумя регулировками: высота спинки и глубина сидения		
	Опора-пиастра: регулировка высоты сидения		

### ОБИВОЧНЫЕ МАТЕРИАЛЫ:

<b>LuxK</b>	— кожа Люкс
<b>НК</b>	— натуральная кожа
<b>КЗ</b>	— заменитель кожи
<b>ФЛОК</b>	— ткань Флок
<b>В</b>	— ткань серии «В»
<b>TW</b>	— ткань серии «TW»
<b>JP</b>	— ткань серии «JP»

# 1 КРЕСЛА РУКОВОДИТЕЛЯ СЕРИИ «УЛЬТРА»

АДМИРАЛ Ультра .....	4
ОДИСЕЙ Ультра.....	4
СИЛУЭТ Ультра .....	5
РОМУЛ Ультра .....	5
ОКСФОРД Б Ультра .....	6
ОКСФОРД М Ультра .....	6
ГАРМОНИЯ Ультра.....	7
БРУНО Ультра.....	7
НАДИР Ультра .....	8
МЕНЕДЖЕР Ультра.....	8
БОЛЕРО Ультра .....	9
СЕНАТОР Ультра .....	9
ВЕНЕЦИЯ Ультра.....	10
КВАНТ Ультра.....	10
КОНСУЛ Ультра .....	11
ПИЛОТ Ультра.....	11
СТИЛЬ Ультра.....	12
ТАНГО Ультра .....	12
АТЛАНТ Ультра.....	13
ЗЕНИТ Ультра .....	13
КВАНТ littel.....	14
АЦТЕК Ультра .....	14
АМИГО 783 Ультра .....	15
АМИГО 511 Ультра .....	15
АМБАСАДОР Ультра.....	16
ВЕГА Ультра .....	16
АМИГО Ультра .....	17
ЧИП Ультра.....	17
ЧИП 192 Ультра.....	18
ЧИП 365 Ультра.....	18



## Адмирал Ультра

СКОРО В ПРОДАЖЕ!



ОБИВОЧНЫЕ МАТЕРИАЛЫ: **K3**

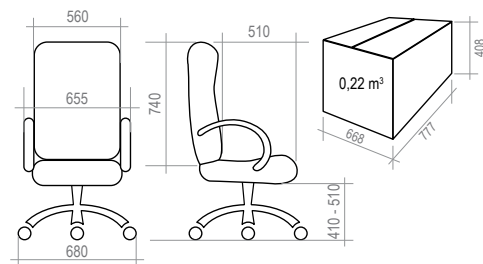

## ОДИСЕЙ Ультра

СКОРО В ПРОДАЖЕ!



ОБИВОЧНЫЕ МАТЕРИАЛЫ: **K3**

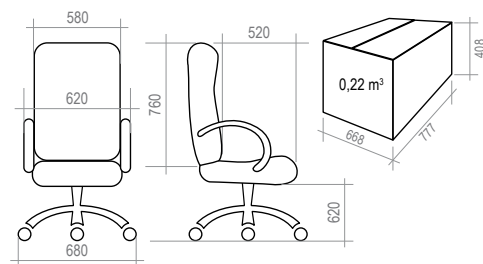

# СИЛУЭТ Ультра

СКОРО В ПРОДАЖЕ!



ОБИВОЧНЫЕ МАТЕРИАЛЫ: **НК, ЗК**

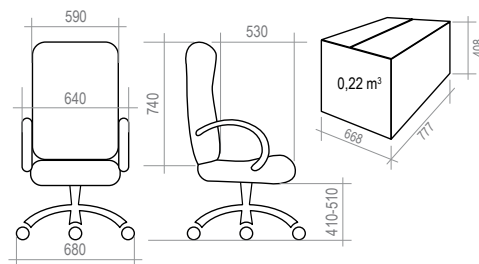

# РОМУЛ Ультра

СКОРО В ПРОДАЖЕ!



ОБИВОЧНЫЕ МАТЕРИАЛЫ: **НК, КЗ**

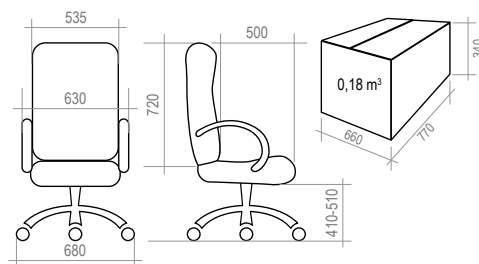

## ОКСФОРД Б Ультра

				MAX ↓ 100	0,18 m <sup>3</sup>	14,3 kg
--	--	--	--	--------------	------------------------	------------

ОБИВОЧНЫЕ МАТЕРИАЛЫ: **К3, TW-сетка**

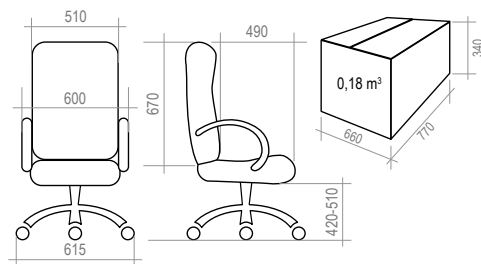

## ОКСФОРД М Ультра

				MAX ↓ 100	0,13 m <sup>3</sup>	10,8 kg
--	--	--	--	--------------	------------------------	------------

ОБИВОЧНЫЕ МАТЕРИАЛЫ: **К3, TW-сетка**

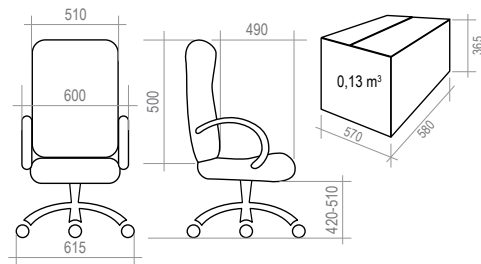



# ГАРМОНИЯ Ультра



ОБИВОЧНЫЕ МАТЕРИАЛЫ: **НК, КЗ, ФЛОК, В, ТВ, JP**

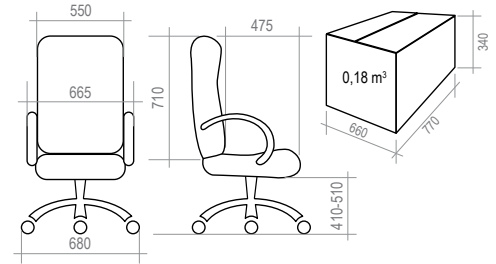

# БРУНО Ультра



ОБИВОЧНЫЕ МАТЕРИАЛЫ: **НК, КЗ**

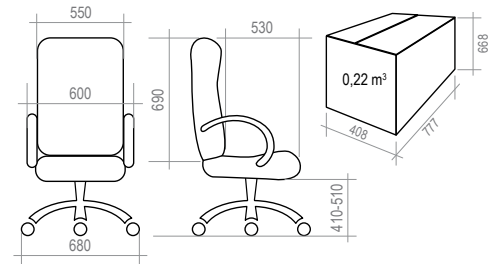



## НАДИР Ультра



ОБИВОЧНЫЕ МАТЕРИАЛЫ: **НК, КЗ**

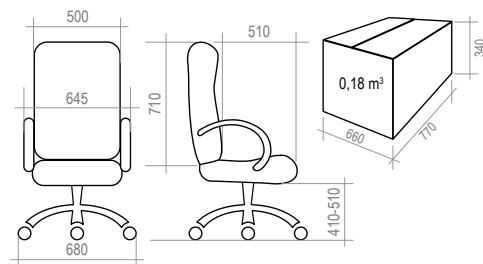

## МЕНЕДЖЕР Ультра



ОБИВОЧНЫЕ МАТЕРИАЛЫ: **НК, КЗ, В**

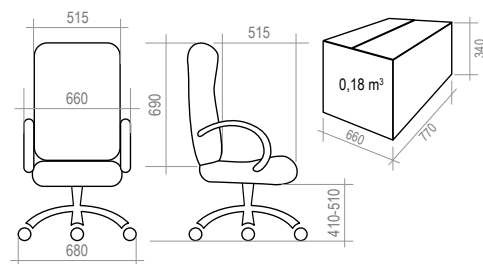

## БОЛЕРО Ультра



ОБИВОЧНЫЕ МАТЕРИАЛЫ: **НК, КЗ**

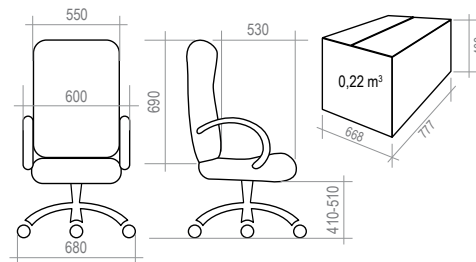

## СЕНАТОР Ультра



ОБИВОЧНЫЕ МАТЕРИАЛЫ: **НК, КЗ**

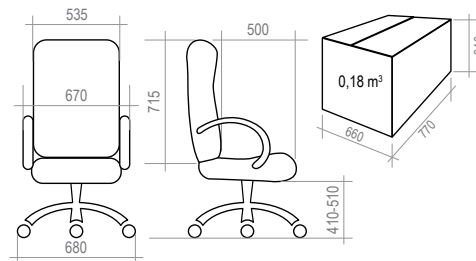

## ВЕНЕЦИЯ Ультра



ОБИВОЧНЫЕ МАТЕРИАЛЫ: **НК, КЗ**

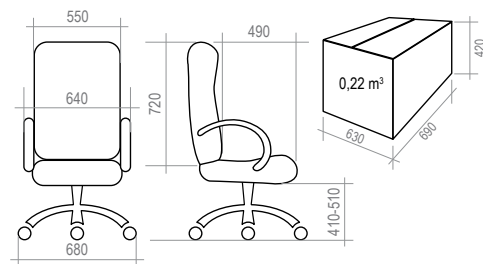

## КВАНТ Ультра



ОБИВОЧНЫЕ МАТЕРИАЛЫ: **НК, КЗ**

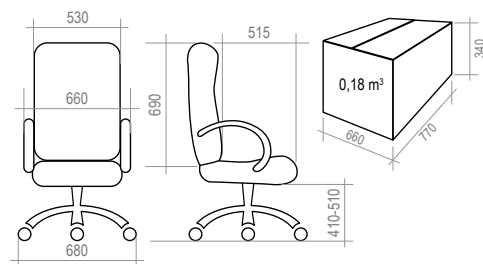

## КОНСУЛ Ультра



ОБИВОЧНЫЕ МАТЕРИАЛЫ: **НК, КЗ**

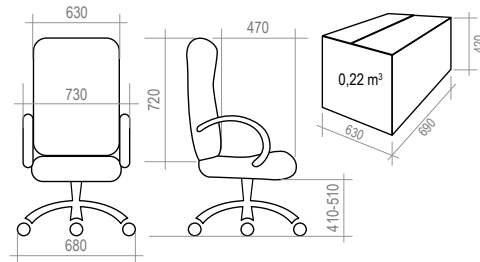

## ПИЛОТ Ультра



ОБИВОЧНЫЕ МАТЕРИАЛЫ: **НК, КЗ**

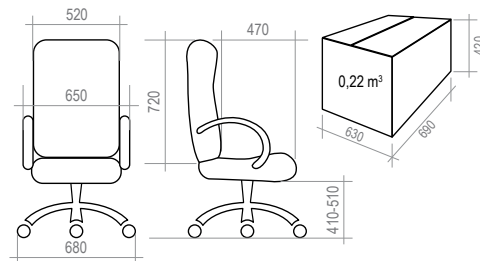

## СТИЛЬ Ультра



ОБИВОЧНЫЕ МАТЕРИАЛЫ: **НК, КЗ**

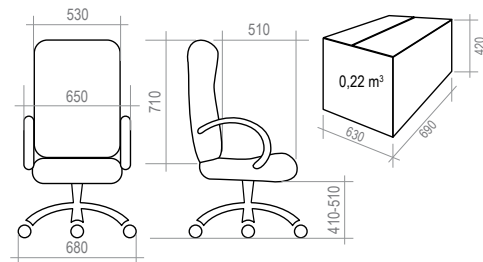

## ТАНГО Ультра



ОБИВОЧНЫЕ МАТЕРИАЛЫ: **НК, КЗ**

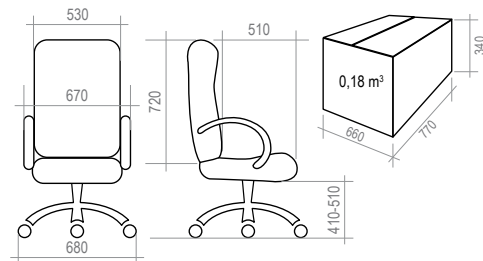



## АТЛАНТ Ультра



ОБИВОЧНЫЕ МАТЕРИАЛЫ: **НК, КЗ**

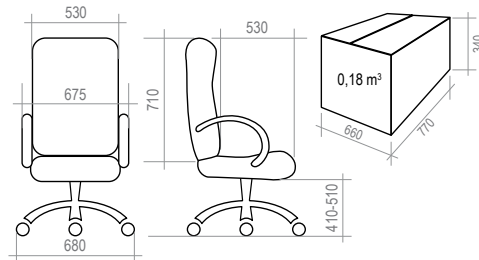

## ЗЕНИТ Ультра



ОБИВОЧНЫЕ МАТЕРИАЛЫ: **НК, КЗ, В**

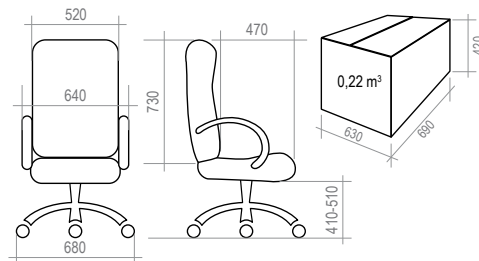



## КВАНТ little



ОБИВОЧНЫЕ МАТЕРИАЛЫ: **НК, КЗ**

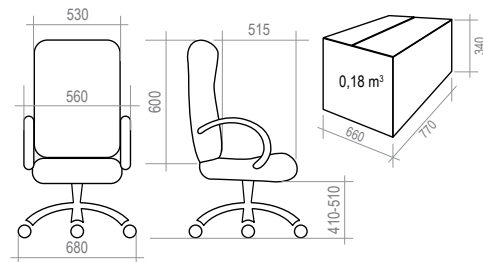

## АЦТЕК Ультра



ОБИВОЧНЫЕ МАТЕРИАЛЫ: **КЗ, В, ТW, JP, ФЛОК**

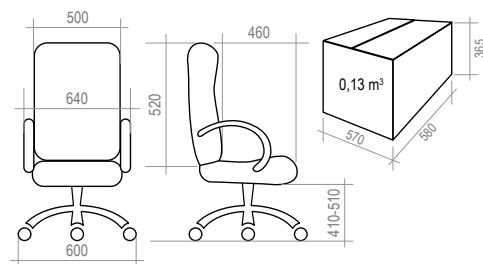

## АМИГО 783



ОБИВОЧНЫЕ МАТЕРИАЛЫ: **TW-сетка (черный+серый)**

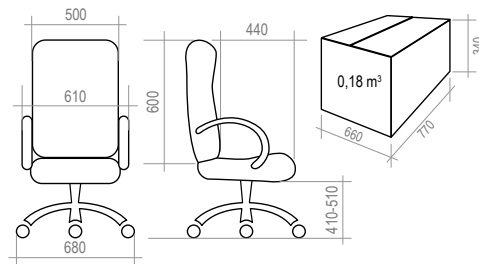

## АМИГО 511



ОБИВОЧНЫЕ МАТЕРИАЛЫ: **КЗ**

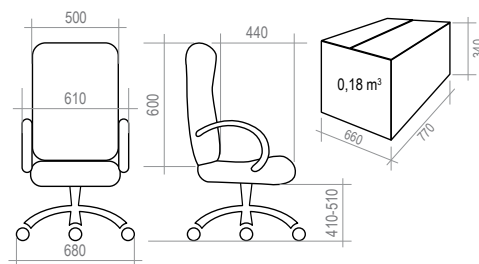

## АМБАСАДОР Ультра



ОБИВОЧНЫЕ МАТЕРИАЛЫ: **КЗ, В, ТW, JP, ФЛОК**

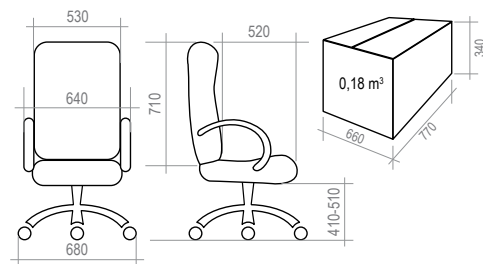

## ВЕГА Ультра



ОБИВОЧНЫЕ МАТЕРИАЛЫ: **КЗ, В, ТW, JP, ФЛОК**

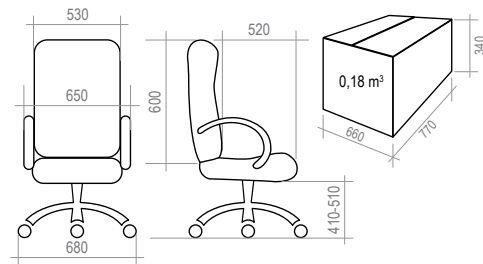

## АМИГО Ультра



ОБИВОЧНЫЕ МАТЕРИАЛЫ: **КЗ, В, ТW, JP, ФЛОК**

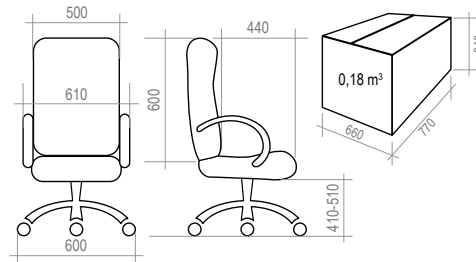

## ЧИП Ультра

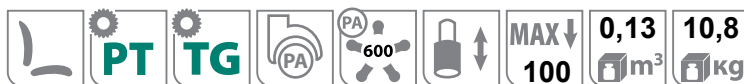

ОБИВОЧНЫЕ МАТЕРИАЛЫ: **НК, КЗ, В**

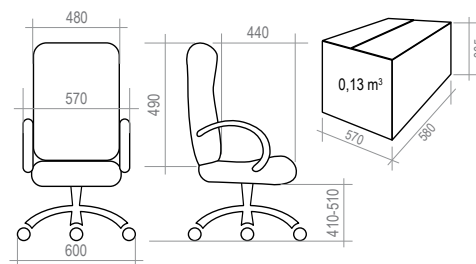

## ЧИП 192 Ультра



ОБИВОЧНЫЕ МАТЕРИАЛЫ: **НК, КЗ, В**

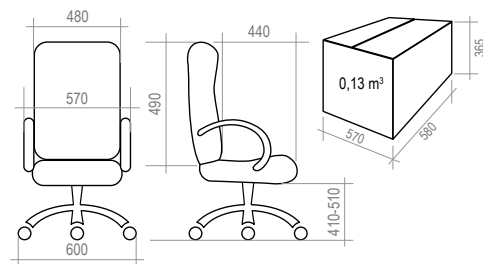

## ЧИП 365 Ультра



ОБИВОЧНЫЕ МАТЕРИАЛЫ: **НК, КЗ, В**

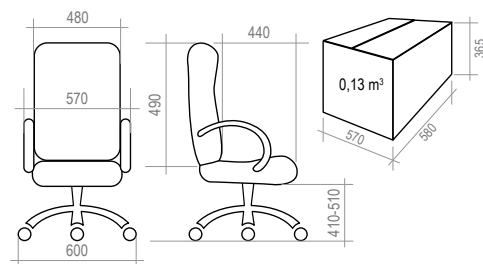

# 2 КРЕСЛА РУКОВОДИТЕЛЯ

ПРЕЗИДЕНТ .....	20
ПРЕМЬЕР .....	20
ВИП .....	21
БОСТОН .....	21
ШЕФ .....	22
ОРХИДЕЯ .....	22
НИКА .....	23
ДИПЛОМАТ .....	23
БОЛЕРО .....	24
НАДИР .....	24
АРТЕКС .....	25
АТЛАНТ .....	25
КОНСУЛ .....	26
ГЕРМЕС .....	26
ПИЛОТ .....	27
ГАРМОНИЯ .....	27
НОВА .....	28
ДАЛИЯ .....	28
МИНИСТР .....	29
СЕНАТОР .....	29
МЕНЕДЖЕР .....	30
ТАНГО .....	30
СВИНГ .....	31
ДАЛАС .....	31
ФИЛАДЕЛЬФИЯ .....	32
ЗЕНИТ .....	32
ТУНИС .....	33





# ПРЕЗИДЕНТ



ОБИВОЧНЫЕ МАТЕРИАЛЫ: **LuxK, НК, КЗ**

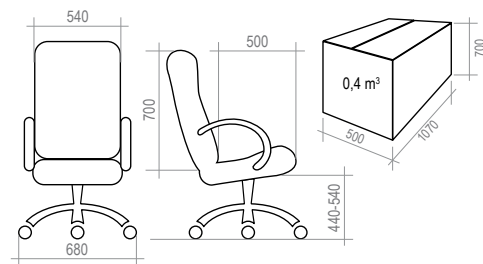

# ПРЕМЬЕР



ОБИВОЧНЫЕ МАТЕРИАЛЫ: **LuxK, НК, КЗ**

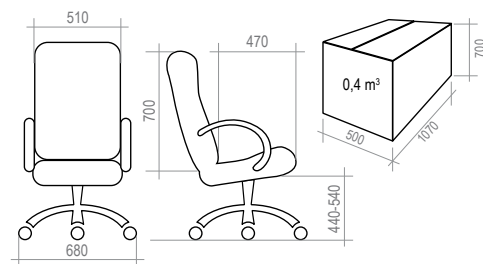

# ВИП



ОБИВОЧНЫЕ МАТЕРИАЛЫ: **LuxK, K3**

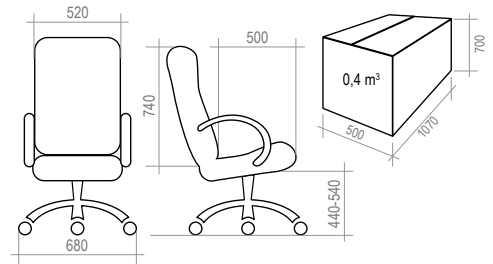

# БОСТОН



ОБИВОЧНЫЕ МАТЕРИАЛЫ: **LuxK, K3**

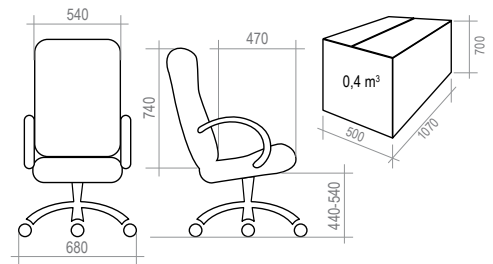

## ШЕФ



ОБИВОЧНЫЕ МАТЕРИАЛЫ: **LuxK, НК, К3**

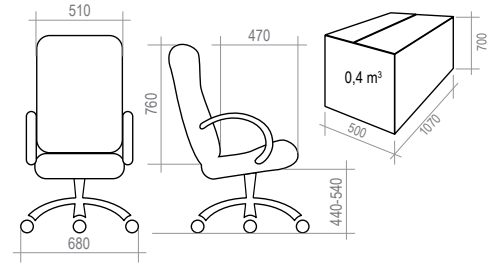

## ОРХИДЕЯ



ОБИВОЧНЫЕ МАТЕРИАЛЫ: **LuxK, К3**

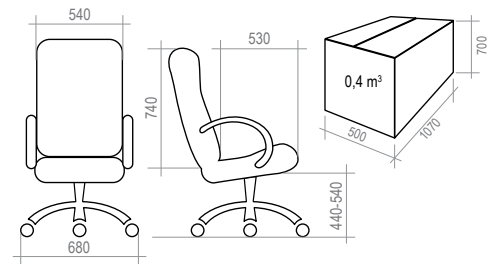

# НИКА



ОБИВОЧНЫЕ МАТЕРИАЛЫ: **LuxK, K3**

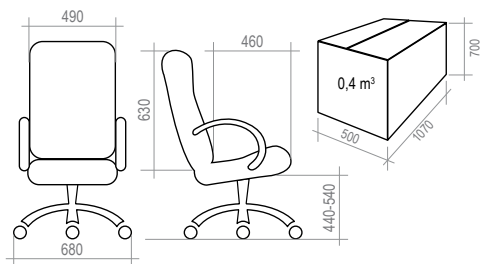

# ДИПЛОМАТ



ОБИВОЧНЫЕ МАТЕРИАЛЫ: **LuxK, НК, K3**

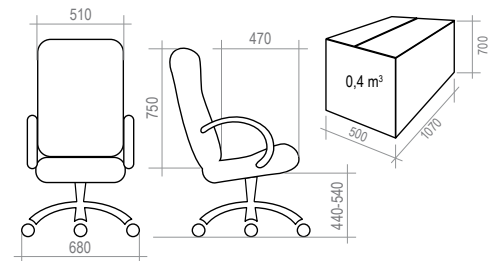

# БОЛЕРО



ОБИВОЧНЫЕ МАТЕРИАЛЫ: **LuxK, НК, КЗ**

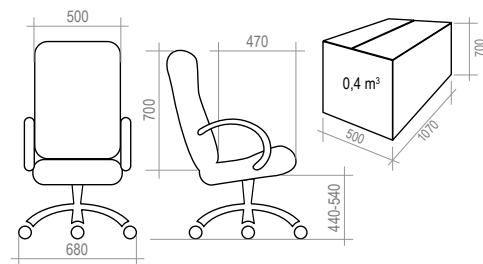

# НАДИР



ОБИВОЧНЫЕ МАТЕРИАЛЫ: **LuxK, НК, КЗ**

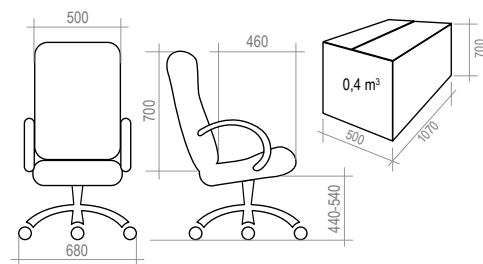



# АРТЕКС



ОБИВОЧНЫЕ МАТЕРИАЛЫ: **LuxK, НК, К3**

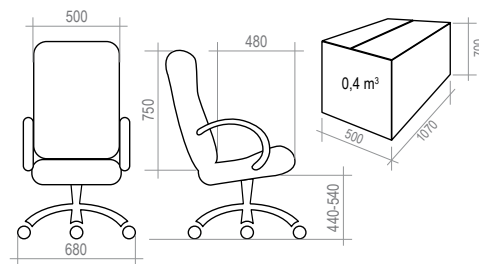

# АТЛАНТ



ОБИВОЧНЫЕ МАТЕРИАЛЫ: **LuxK, НК, К3**

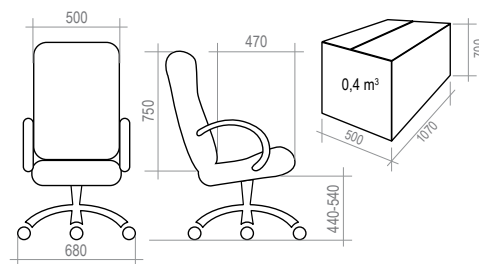



# КОНСУЛ



ОБИВОЧНЫЕ МАТЕРИАЛЫ: **LuxK, НК, К3**

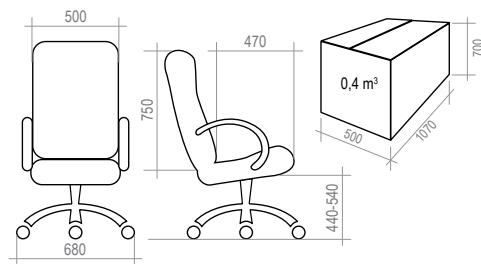

# ГЕРМЕС



ОБИВОЧНЫЕ МАТЕРИАЛЫ: **LuxK, НК, К3**

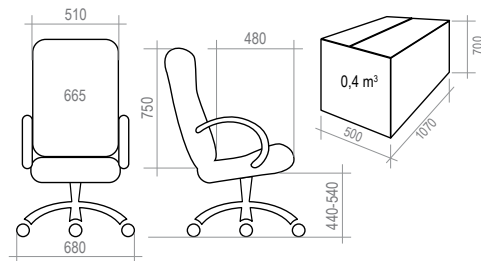

# ПИЛОТ



ОБИВочНЫЕ МАТЕРИАЛЫ: **LuxK, НК, КЗ**

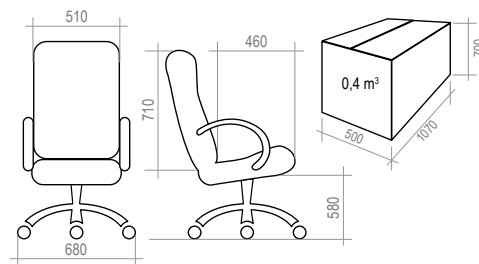

# ГАРМОНИЯ



ОБИВочНЫЕ МАТЕРИАЛЫ: **НК, КЗ**

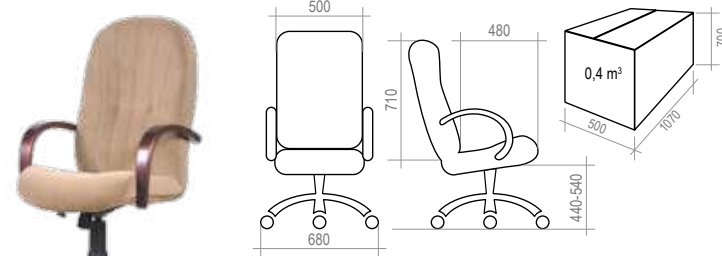

# НОВА



ОБИВОЧНЫЕ МАТЕРИАЛЫ: **LuxK, НК, К3**

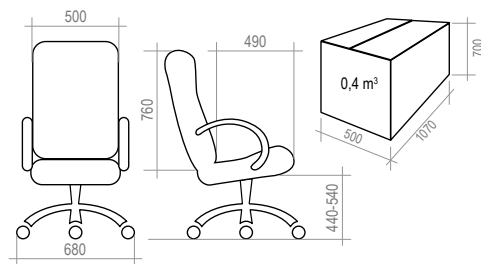

# ДАЛИЯ



ОБИВОЧНЫЕ МАТЕРИАЛЫ: **LuxK, К3**

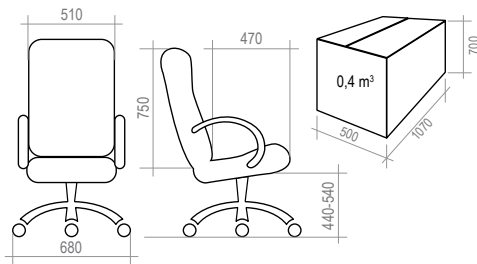

# МИНИСТР



ОБИВОЧНЫЕ МАТЕРИАЛЫ: **LuxK, НК, К3**

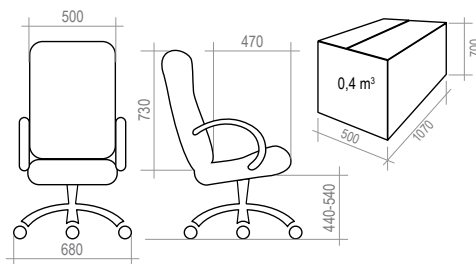

# СЕНАТОР



ОБИВОЧНЫЕ МАТЕРИАЛЫ: **LuxK, НК, К3**

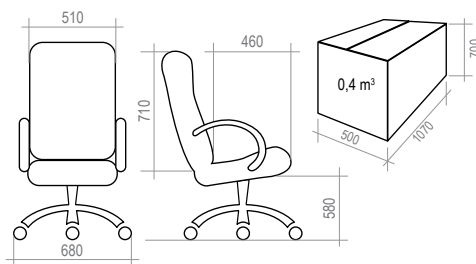

# МЕНЕДЖЕР



ОБИВОЧНЫЕ МАТЕРИАЛЫ: **НК, КЗ, В**

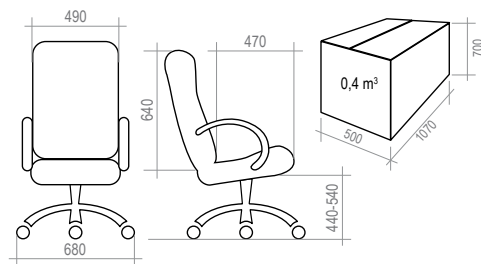

# ТАНГО



ОБИВОЧНЫЕ МАТЕРИАЛЫ: **НК, КЗ**

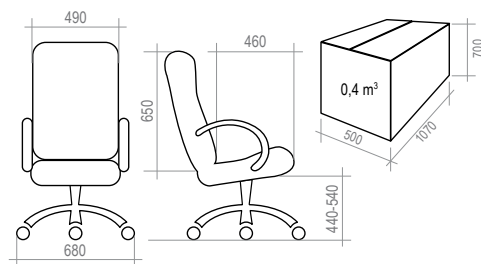



# СВИНГ



ОБИВОЧНЫЕ МАТЕРИАЛЫ: **НК, КЗ**

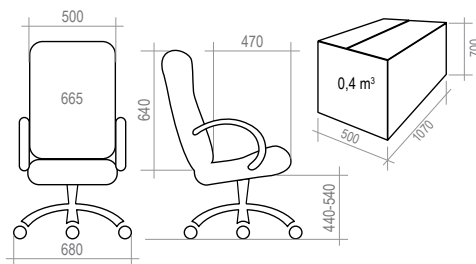

# ДАЛАС



ОБИВОЧНЫЕ МАТЕРИАЛЫ: **НК, КЗ**

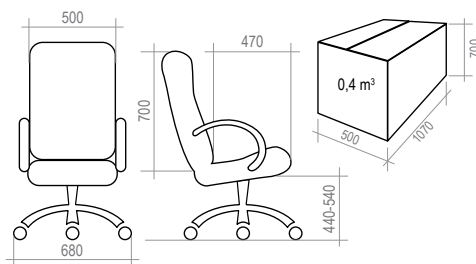



# ФИЛАДЕЛЬФИЯ



ОБИВОЧНЫЕ МАТЕРИАЛЫ: **LuxK, НК, КЗ**



# ЗЕНИТ



ОБИВОЧНЫЕ МАТЕРИАЛЫ: **НК, КЗ**



# ТУНИС



ОБИВОЧНЫЕ МАТЕРИАЛЫ: **LuxK, K3**

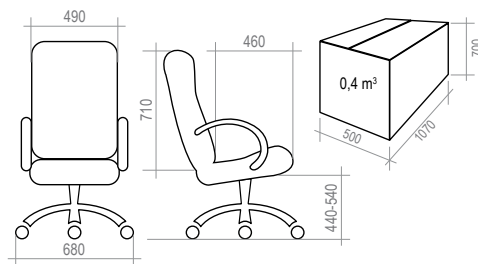

Кресла руководителя

# 3 КРЕСЛА ОПЕРАТОРА

МАРК БОСТОН.....	35
МАРК ФАКТОР.....	35
ИРИС.....	36
ГИГА.....	36
ЭМИР .....	37
БИЛЛ.....	37
ДИДАЛ.....	38
КВАДРО .....	38
ФРЕГАТ .....	39
ЭКСПЕРТ.....	39
ФЛЕШ .....	40
ГРАНД.....	40
ЛЕДА.....	41
ЭМИР ПРОФИ.....	41
ЮПИТЕР .....	42
МАРТИН.....	42
ПРЕСТИЖ С.....	43
ПРЕСТИЖ .....	43
МЕТРО .....	44
РЕГАЛ .....	44
ГРЕТА .....	45
ЛОГИКА.....	45
ФОРМУЛА .....	46



# МАРК БОСТОН

СКОРО В ПРОДАЖЕ!



ОБИВОЧНЫЕ МАТЕРИАЛЫ: **НК, К3**

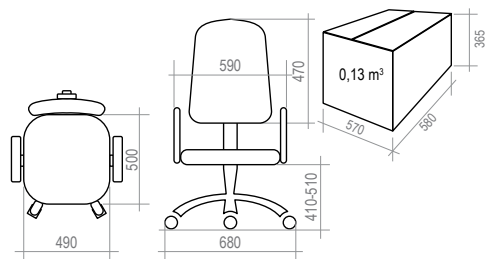

# МАРК ФАКТОР

СКОРО В ПРОДАЖЕ!



ОБИВОЧНЫЕ МАТЕРИАЛЫ: **НК, К3**

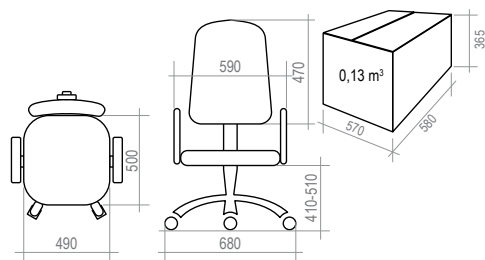

## ИРИС



ОБИВОЧНЫЕ МАТЕРИАЛЫ: **B, TW, JP**

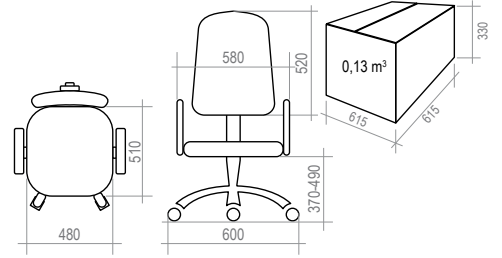

## ГИГА



ОБИВОЧНЫЕ МАТЕРИАЛЫ: **TW**

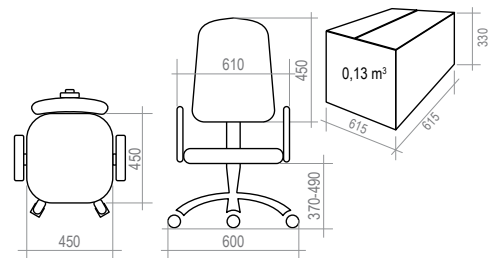



## ЭМИР



ОБИВОЧНЫЕ МАТЕРИАЛЫ: ТУ, ЈР, ФЛОК

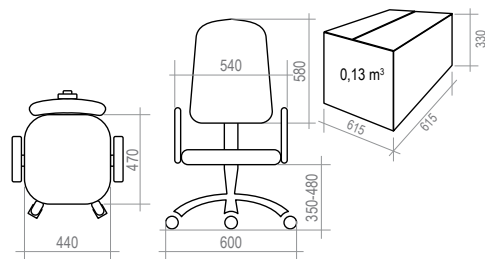

## БИЛЛ



ОБИВОЧНЫЕ МАТЕРИАЛЫ: В, ЈР, ФЛОК

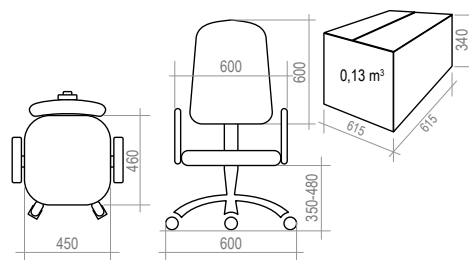

## ДИДАЛ



ОБИВОЧНЫЕ МАТЕРИАЛЫ: **JP, ФЛОК**

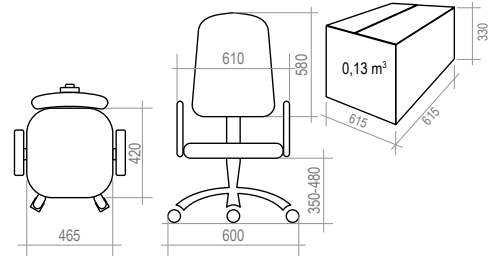

## КВАДРО



ОБИВОЧНЫЕ МАТЕРИАЛЫ: **TW, JP**

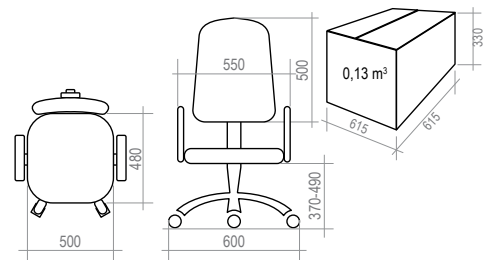

# ФРЕГАТ



ОБИВОЧНЫЕ МАТЕРИАЛЫ: **TW, JP**

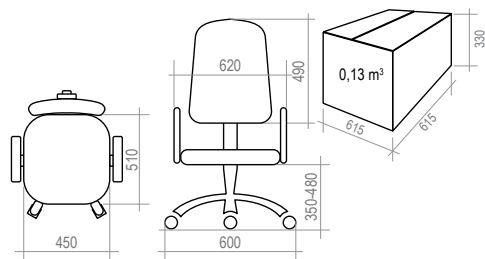

# ЭКСПЕРТ



ОБИВОЧНЫЕ МАТЕРИАЛЫ: **В, TW, JP, ФЛОК**

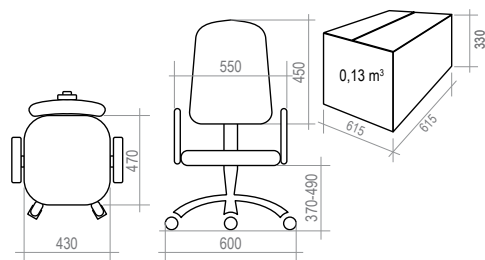

## ФЛЕШ



ОБИВОЧНЫЕ МАТЕРИАЛЫ: В, ТW, JP, ФЛОК

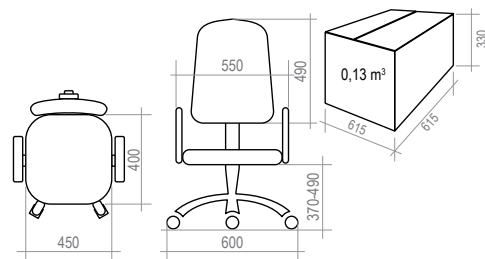

## ГРАНД



ОБИВОЧНЫЕ МАТЕРИАЛЫ: В, ФЛОК

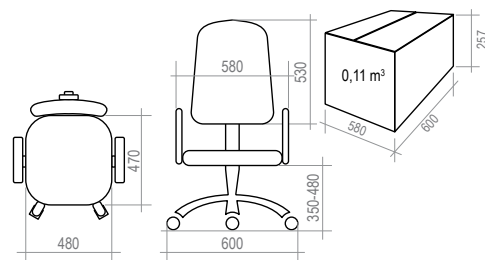

# ЛЕДА



ОБИВОЧНЫЕ МАТЕРИАЛЫ: В, ТW, JP, ФЛОК

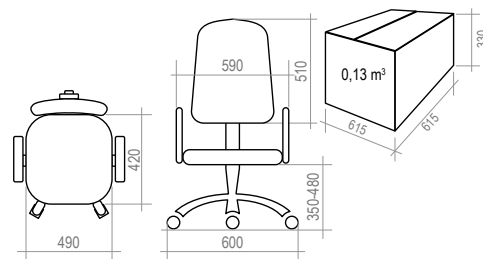

# ЭМИР PROFИ



ОБИВОЧНЫЕ МАТЕРИАЛЫ: В, ТW, JP, ФЛОК

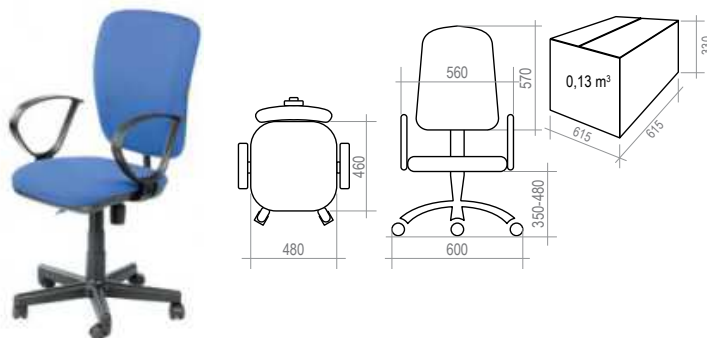



## ЮПИТЕР



ОБИВОЧНЫЕ МАТЕРИАЛЫ: В, ТW, JP, ФЛОК

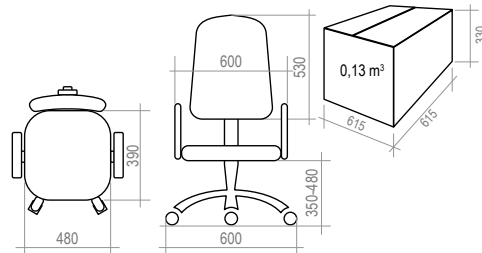

## МАРТИН



ОБИВОЧНЫЕ МАТЕРИАЛЫ: В, ТW, JP, ФЛОК

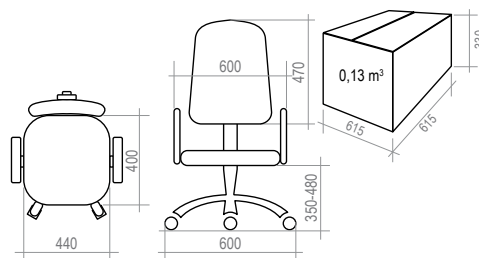

# ПРЕСТИЖ С



ОБИВОЧНЫЕ МАТЕРИАЛЫ: **КЗ, В, ТW, JP, ФЛОК**

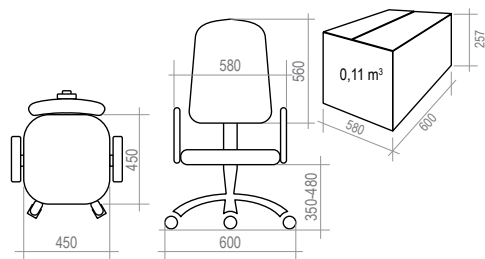

# ПРЕСТИЖ



ОБИВОЧНЫЕ МАТЕРИАЛЫ: **КЗ, В, ТW, JP, ФЛОК**

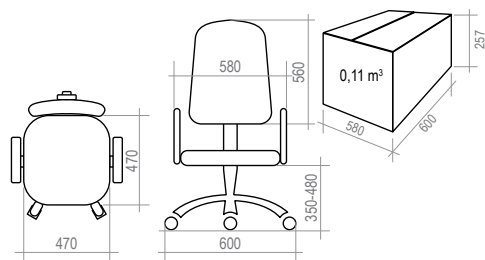

## МЕТРО



ОБИВОЧНЫЕ МАТЕРИАЛЫ: НК, КЗ, В, TW, JP, ФЛОК

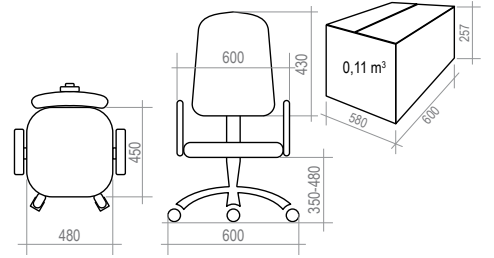

## РЕГАЛ



ОБИВОЧНЫЕ МАТЕРИАЛЫ: В, ФЛОК, Т

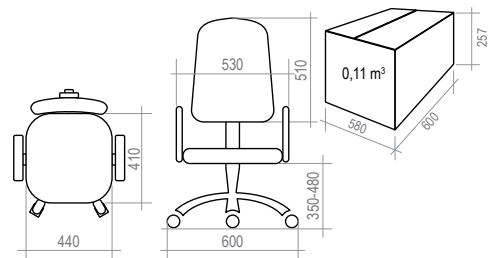

# ГРЕТТА



ОБИВОЧНЫЕ МАТЕРИАЛЫ: **КЗ, В, ТW, ФЛОК, Т**

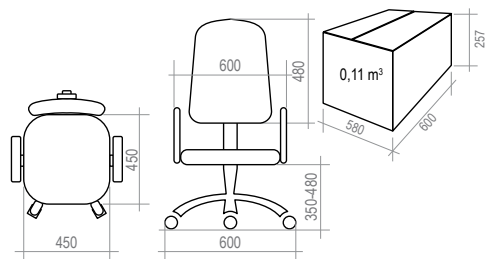

# ЛОГИКА



ОБИВОЧНЫЕ МАТЕРИАЛЫ: **В, ФЛОК, Т**

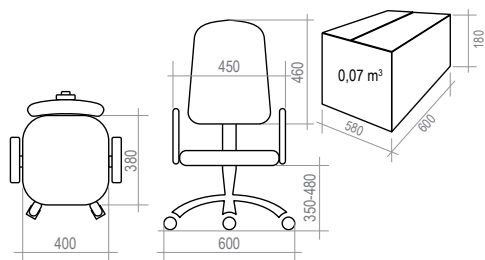

# ФОРМУЛА



ОБИВОЧНЫЕ МАТЕРИАЛЫ: **КЗ, В, ТW, ФЛОК, Т**

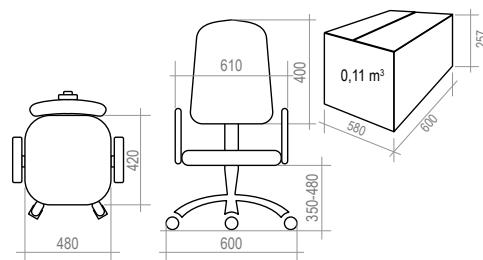



# 4 СТУЛЬЯ ДЛЯ ПОСЕТИТЕЛЕЙ

ГРАФ .....	47
ДЖУНО ЛЮКС .....	47
ДЖУНО.....	47
САМБА.....	48
ИЗО ХОРМ.РАМА .....	48
ИЗО ЧЕРНАЯ РАМА.....	48
ДЕЙЗИ .....	49
СМ-7 .....	49





## ГРАФ

ОБИВОЧНЫЕ МАТЕРИАЛЫ:  
НК, КЗ

MAX ↓ 0,25 16  
120 m³ kg

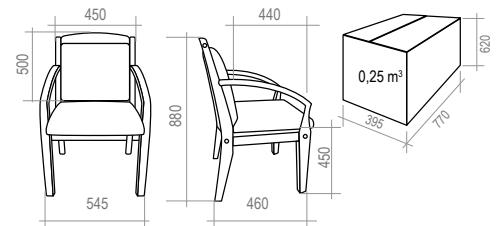

## ДЖУНО ЛЮКС

ОБИВОЧНЫЕ МАТЕРИАЛЫ:  
НК, КЗ

MAX ↓ 0,25 10  
100 m³ kg

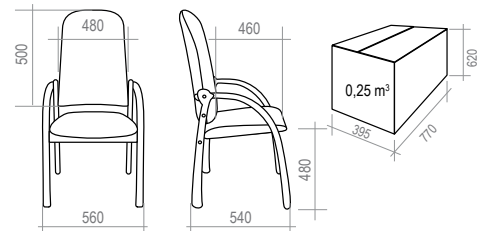

## ДЖУНО

ОБИВОЧНЫЕ МАТЕРИАЛЫ:  
НК, КЗ

MAX ↓ 0,25 9  
100 m³ kg

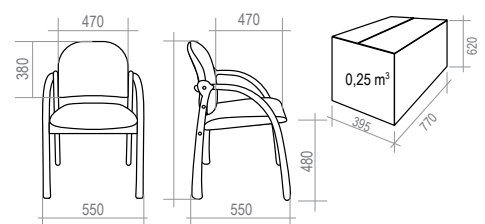



## САМБА

ОБИВОЧНЫЕ МАТЕРИАЛЫ:

**КЗ**

**MAX↓**  
**100**

**0,33**  
**m³**

**9,5**  
**kg**

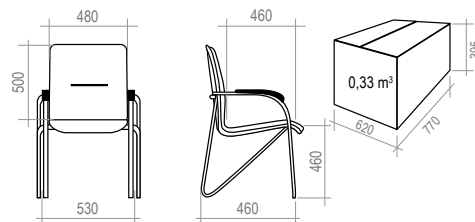

## ИЗО ХРОМ. РАМА

ОБИВОЧНЫЕ МАТЕРИАЛЫ:

**КЗ, В, ТW, JP, ФЛОК**

**15**

**MAX↓**  
**100**

**0,7**  
**m³**

**6,6**  
**kg**

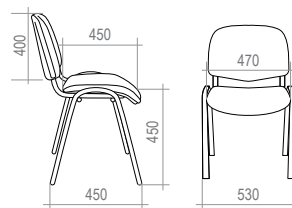

## ИЗО ЧЕРНАЯ РАМА

ОБИВОЧНЫЕ МАТЕРИАЛЫ:

**КЗ, В, ТW, JP, ФЛОК**

**15**

**MAX↓**  
**100**

**0,7**  
**m³**

**6,6**  
**kg**

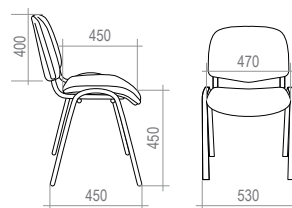

# ДЕЙЗИ

ОБИВОЧНЫЕ МАТЕРИАЛЫ:  
КЗ, В, ТW, JP, ФЛОК

 15	MAX ↓ 100	0,7  m <sup>3</sup>	6,6  kg
--	--------------	---	---

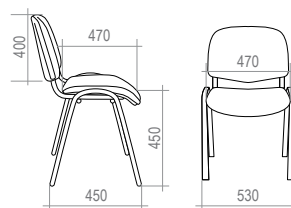

# СМ-7

ОБИВОЧНЫЕ МАТЕРИАЛЫ:  
КЗ, В, ТW, JP, ФЛОК

 15	MAX ↓ 80	0,7  m <sup>3</sup>	5,1  kg
--	-------------	---	---

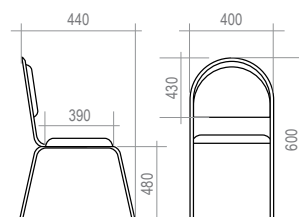

# 5 ОТДЕЛОЧНЫЕ МАТЕРИАЛЫ

НАТУРАЛЬНАЯ КОЖА.....	51
ЗАМЕНИТЕЛЬ КОЖИ.....	51
Ткани серии «В» .....	52
Ткани серии «ТW» .....	52
Ткани серии «JP» .....	52
Ткани серии «ФЛОК» .....	53
Цвета дерева .....	53





## НАТУРАЛЬНАЯ КОЖА ДЛЯ КРЕСЕЛ РУКОВОДИТЕЛЯ



БЕЖЕВЫЙ  
1010-Y20R

БЕЖЕВЫЙ  
1515-Y40R

БОРДО  
6030-R10B

КОРИЧНЕВЫЙ  
6030-Y70R



СИНИЙ  
7020-R70B

ЗЕЛЕНЫЙ  
8010-B90G

ЧЕРНЫЙ  
8500-N

## ЗАМЕНИТЕЛЬ КОЖИ ДЛЯ КРЕСЕЛ ОПЕРАТОРА



БЕЖ

ЗЕЛЕНЫЙ

КОРИЧНЕВЫЙ

КРАСНЫЙ

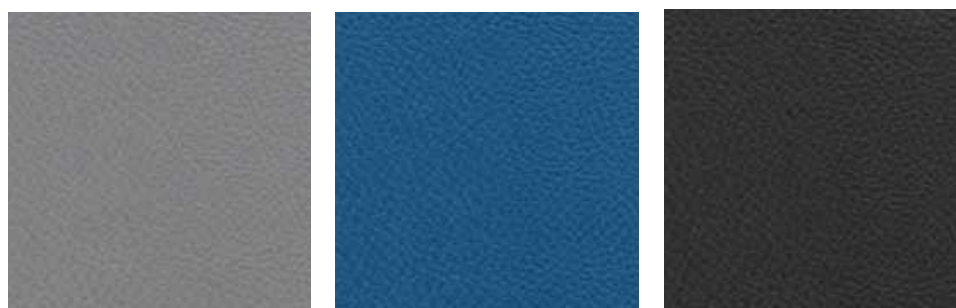

СЕРЫЙ

СИНИЙ

ЧЕРНЫЙ

## ТКАНИ СЕРИИ «В»



B-3



B-4



B-9

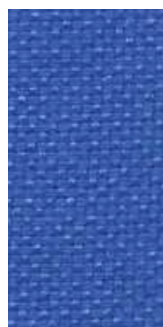

B-10



B-12



B-14



B-18



B-20



B-21



B-22

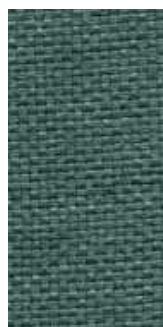

B-27



B-28



B-40



2 A

## ТКАНИ СЕРИИ «TW»



TW-10

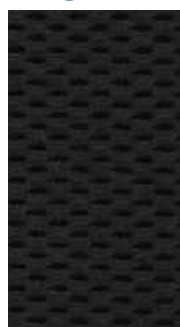

TW-11



TW-12

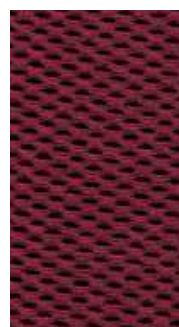

TW-13

## ТКАНИ СЕРИИ «JP»



JP 15-1

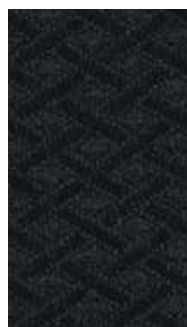

JP 15-2



JP 15-3



JP 15-4



JP 15-5



JP 15-6



## ТКАНИ СЕРИИ «ФЛОК»



FI-2 бежевый



FI-09 бордовый



FI-10 зеленый



FI-11 темно-синий



FI-12 синий



FI-17 коричневый



FI-23 серый



FI-black черный

## ЦВЕТА ДЕРЕВА (кресла руководителя Экстра)



БУК



ВИШНЯ



ОЛЬХА



ТЕМНЫЙ ОРЕХ



ПАЛИСАНДР



ВЕНГЕ



МАХАГОН



МУКС



Тел.: (495) 788-75-89, 788-76-44, 788-76-84

[www.chairs.ru](http://www.chairs.ru)

[info@chairs.ru](mailto:info@chairs.ru)